



**BCATS**  
BUILDING, CONSTRUCTION  
AND ALLIED TRADES SKILLS

**Level**  
**2**

# Using materials

Assessment resource

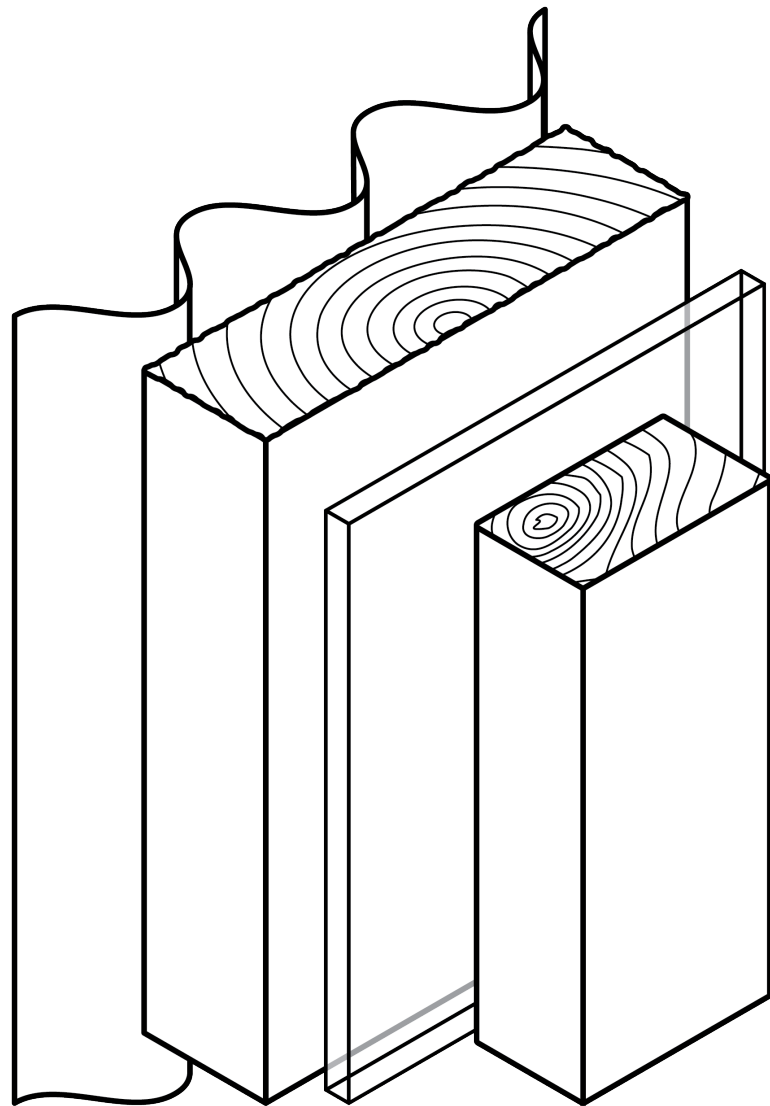

**5 credits**

Skill Standard 40552 (v1)

**Use materials for a BCATS project**

Learner name: \_\_\_\_\_

BCATS project: \_\_\_\_\_

**BCITO**  
He Hunga Hanga Mātou  
building people

## Assessment: Using materials

### Learner instructions

This assessment is about using materials for a BCATS project.

You need to show you can do these things without being prompted:

- Identify properties and storage requirements of materials that make them appropriate for your project.
- Use materials carefully and correctly for your project.
- Dispose of any material waste thoughtfully, and store materials safely.

Over the page, you will see what you need to do for this assessment.



Your teacher will observe you using the materials for your project. They will provide comments in this assessment resource as evidence to support their observations.

You will need to provide the following evidence to support this. Submit it using myBCITO or the process at your school/organisation.



A completed *Materials ID* worksheet (pgs. 3 – 5 in this assessment resource).

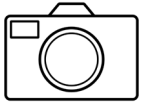

Photos that clearly show first use of your materials through to the finished product.

Use the assessment checklist in this resource to keep track of the evidence you have collected.

---

The grade you are awarded will be based on your ability to carefully consider materials for your project, and use the materials skilfully with minimal wastage.

---

## Worksheet: Materials ID

For this assessment activity, you need to identify materials you will use for your project. It is an open book activity.

Looking into the properties, handling, and storage requirements for different materials helps you choose the best ones for your project.

Have a look at your project brief and then fill in the tables on the next page with this information.



- Name the project you will be creating and list all the materials you need.
- Select the specific timber and other materials you will use. Explain why they are the most suitable for your project.
- Describe the storage requirements for each material.

Example answers have been given below.

**Project:** *Dog kennel with a run*

Materials you will need	Requirements of the materials
<i>Timber</i>	<i>For the frame, cladding, and decking slats – needs to be weatherproof and not prone to splinters.</i>
<i>Roofing</i>	<i>Weatherproof and ideally provide some insulation.</i>
<i>Some kind of mesh for the run</i>	<i>Needs to be resistant to chewing, rustproof, small enough to prevent escape, and have no sharp edges.</i>
<i>Hinges</i>	<i>Heavy duty as they will be used a lot, rustproof.</i>
<i>Finishing stain</i>	<i>Needs to be weatherproof and non-toxic.</i>

Specific materials you will use for your project	How does this material meet the project needs? Why is it the most suitable?	Storage requirements
<i>H3.2 pine fencing rail</i>	<i>This timber is durable and reasonably cheap. I'm using H3.2 because this is best for outdoor use.</i>	<i>This timber should be laid flat and kept dry.</i>
<i>H3.2 pine decking</i>	<i>This timber is similar to the fence rails but has a dressed finish so there shouldn't be any splinters.</i>	<i>As above.</i>
<i>etc.</i>		





## Use materials

You need to show you can do these things for your project without being prompted.

- Check the project brief for correct material measurements and quantities needed.
- Measure and cut the materials accurately.
- Handle and use the materials safely.
- Minimise the amount of material you waste, and dispose of any waste thoughtfully.



Your teacher will observe you using the materials for your project.

Below is the other evidence you need to collect during your practical work. You should work with your teacher to make sure you've provided everything needed.



Photos that clearly show first use of your materials through to the finished product.

## Assessment checklist: Using materials

To be completed by the learner and the teacher.

Assessment activity	Evidence needed	Date all evidence collected (Learner to complete)	Teacher sign-off
Materials ID	A completed <i>Materials ID</i> worksheet.		
Use materials	Photos that clearly show first use of your materials through to the finished product.		

**Note:** A copy of the project brief must also be included in your overall portfolio of evidence.

## Teacher observation: Using materials

Learner name: \_\_\_\_\_

Project: \_\_\_\_\_

### Teacher instructions

Below are criteria for the available grades.

Not Achieved	Achieved	Merit	Excellence
Materials are not used appropriately for a BCATS project.	Use materials for a BCATS project.	Efficiently use materials for a BCATS project.	Skilfully use materials for a BCATS project.



**Provide comments on the learner's ability to meet the following assessment criteria, considering everything you observed throughout the project.**

Project brief is used to identify material types, measurements, and quantities.	
Properties of materials that make them appropriate for the project, and storage requirements, are identified.	
Timber and other materials are used safely for the project, and waste is dealt with thoughtfully.	



## Grade awarded: Using materials

### Teacher instructions

After considering all the evidence collected, enter the grade you will award for Skill Standard 40552, with comments that explain your decision.

Final grade		Date	
<p><b>Justification for final grade</b> (Provide overall comments, considering all evidence collected)</p>			

### Teacher and learner sign-off

		Date
<p><b>Learner signature</b> (Grade received and accepted)</p>		
<p><b>Teacher sign-off</b></p>	<p>Name: _____ Signature: _____</p>	